

# AVALON SETTING



Metal Art Limited  
Street & Park Furniture

## DESCRIPTION

A 4 slat table combined with two x 3 slat bench seats to create a functional picnic setting.

The Avalon uses durable recycled plastic slats as standard, on a robust galvanised support frame available powder coated in any standard colour. Optional fixing method.

## SLAT DIMENSIONS/SEAT LENGTH

Seat slat section: 90 x 40mm  
Table slat section: 200 x 40mm  
Length: 1750mm

## SLAT MATERIAL

- Timber oiled  
(Eucalyptus Saligna)
- Timber mahogany stained  
(Eucalyptus Saligna)
- 100% recycled plastic
  - Green
  - Grey
  - Brown
  - Blue

## MOUNTING

- Surface fixed
- In ground fixed

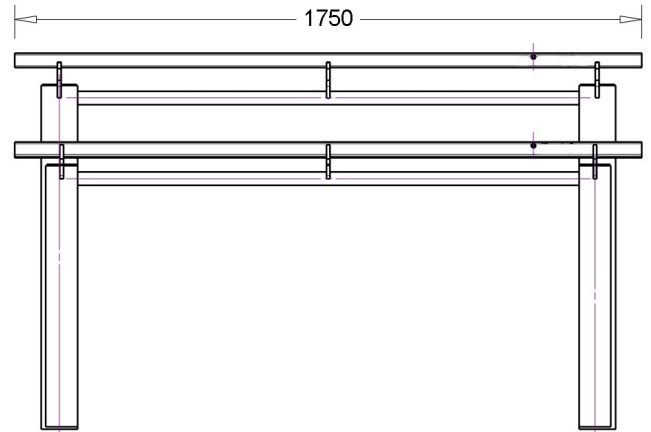

Side view, in ground fixed

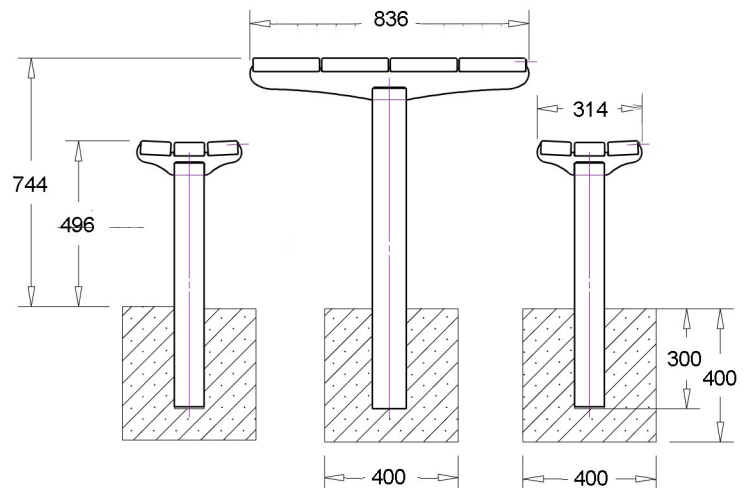

End view, in ground fixed



Metal Art Ltd

51 Port Road, Seaview  
Wellington, New Zealand  
Ph +64 4 939-6666  
Fax +64 4 939-6696  
info@metalart.co.nz  
www.metalart.co.nz